

# EARTH ASSURANCE CLAMP - With Cable

The EAC200 series for earth assurance clamp ensures correct grounding of truck chassis to eliminate static build-up.

The EAC200 series earth assurance clamp is used to discharge the static accumulation of hazardous products during storage and transportation.

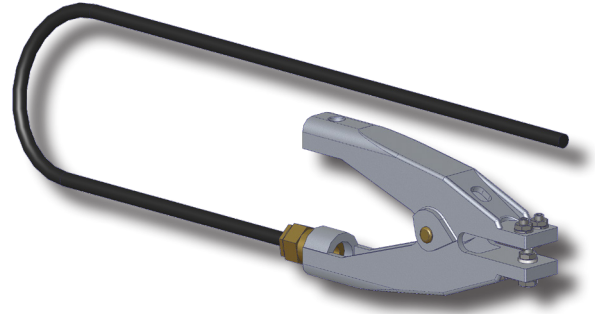

*EAC201: Earth Assurance Clamp.*

## Key Features

- 8m cable length supplied.
- Can be supplied with straight cable or self-storing (curly) cable.

## Technical Information

Operation	Before connecting any other equipment to truck, attach clamp to a suitable grounding point no more than 12.7 mm (1/2") thick.
Dismantle	Not recommended
Adjustment	None required.
Materials	Clamp body: cast aluminium Cable: polyurethane sheathed Contacts: cone point grub screws – stainless steel
Weight	Clamp & cable: 1.3 kg 8m cable length supplied
Technical Data	EAC201S has straight cable EAC202S has self-storing (curly) cable
Associated Equipment	RM140D: Overfill monitor (typical configuration for Australian market). RM140E: Overfill monitor (typical configuration for Global markets).

## Ordering Information

- **EAC201S:** Earth Assurance clamp with 8m straight cable.
- **EAC202S:** Earth Assurance clamp with 8m self-storing (curly) cable.



# EAC20xS EARTH ASSURANCE CLAMP

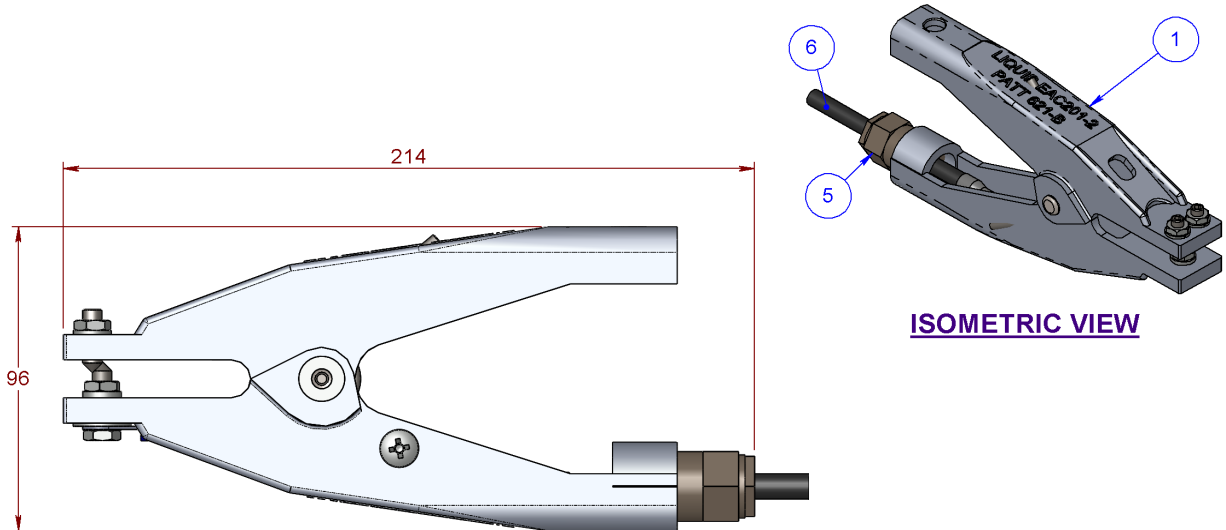

**LEFT HAND VIEW**

**ISOMETRIC VIEW**

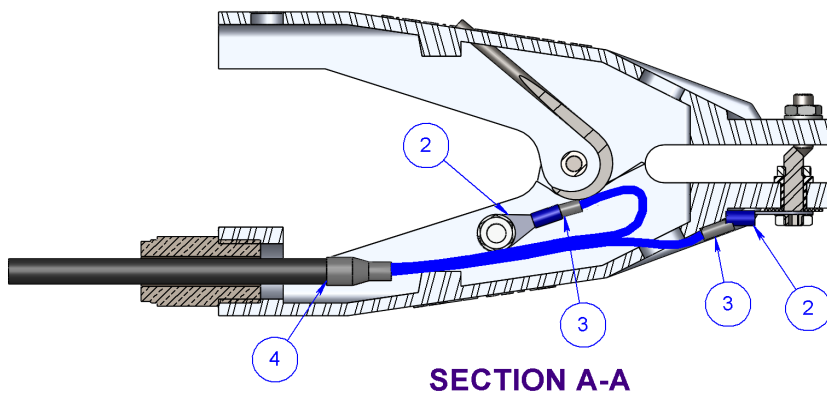

**SECTION A-A**

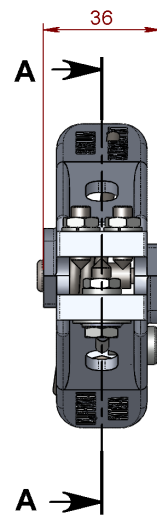

**FRONT VIEW**

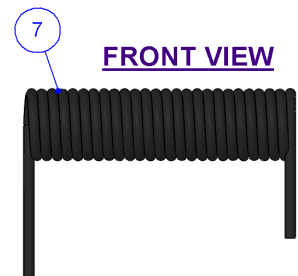

56060 SELF-STORE  
CABLE USED ON EAC202

ITEM NO.	PART NUMBER	DESCRIPTION	EAC201S	EAC202S	MATERIAL
1	EAC201-3S	EARTH CLAMP	1	1	ALUMINIUM
2	1412	EYE TERMINAL	2	2	Z/P STEEL
3	6892	HEAT SHRINK - 6/2	2	2	PLASTIC
4	5103	HEATSHRINK TUBE	1	1	PLASTIC
5	5531	GLAND CABLE M20 x 1.5	1	1	N/P BRASS
6	6871	CABLE 3 CORE	1	-	POLYURETHANE
7	56060	CABLE 2 CORE SELF-STORE	-	1	POLYURETHANE

METERS - VALVES - VENTS - MANHOLES - HOSEREELS - OVERFILL PROTECTION - LOADING ARMS - ELECTRONIC DIPSTICKS