

AIV3 Air Interlock Valve

Liquip's pneumatic interlock valve provides a pneumatic interlock on API adaptors, vapour adaptors or interlock bars.

The AIV3 3/2 way air valve is used to identify that a hose has been connected to the adaptor for either loading or discharge.

It can also form part of the pneumatic circuit to ensure the tank truck breaks are on, the emergency valve is open and the vapour vents are open before product can flow.

Commonly mounted to API490 series adaptors, VCM450 and GC300 series guard bar.



Key Features

- 3 port pneumatic spool valve.
- Normally close operation.
- Air supply to Port 1.
- Actuated air signal out from Port 2.
- Exhaust from Port 3.

Ordering Information

AIV3 Air Valve 3 Port with Push Button.

Technical Information

| | |
|----------------------|--|
| Ports | 3 x 1/4" BSP ports |
| Operating Pressure | 850 kPa maximum operating pressure. |
| Mounting | Standard Mounting to API490 adaptors VCM450 and GC300 guard bar. |
| Weight | 200g |
| Dismantle | Unscrew end plug and button actuator. Remove valve spool and inspect O-Rings. |
| Adjustment | Set length with screw (item 9) & lock with Nut (11). Button (3) can be replaced with other contacts if required such as striker plate for vapour adaptor or bolt (12) for GC300. See following pages for further info. |
| Materials | Body - Aluminium Spool - Stainless Steel Seals - Polyurethane wiper seal, Viton O-rings |
| Associated Equipment | <ul style="list-style-type: none"> • GC300 Series: Vapour Gates • VCM450: Vapour Adaptor 4" Camlock • API490 Series: API adaptors |

AIR INTERLOCK VALVE

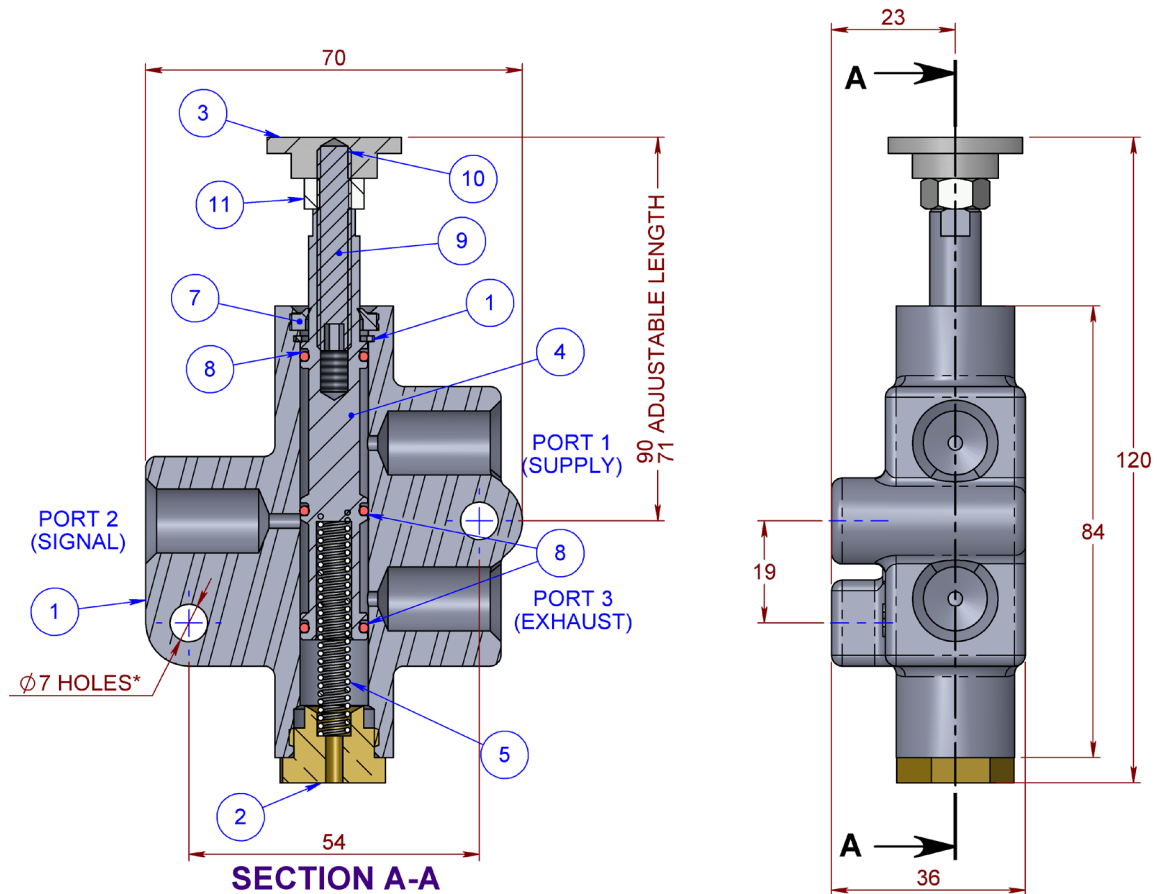

* MOUNTING BOLTS SUPPLIED SEPARATELY

NOTES:

1. ALL PORTS G $\frac{1}{4}$ (BSP)
2. BOLT 0002 (NOT SHOWN) SUPPLIED AS ALTERNATIVE BUTTON

| 12 | 0002 | BOLT | 1 | Z/P STEEL |
|------|-------------|-------------------|------|---------------|
| 11 | 0128 | NUT HEX | 1 | Z/P STEEL |
| 10 | 3361 | LOCTITE | 1 | CYANOACRYLATE |
| 9 | 6678 | GRUBSCREW | 1 | Z/P STEEL |
| 8 | 4512 | O-RING | 3 | VITON A |
| 7 | 4604 | D STYLE ROD WIPER | 1 | POLYURETHANE |
| 6 | 4362 | CIRCLIP | 1 | SPRING STEEL |
| 5 | 4432 | SPRING RETURN | 1 | SPRING STEEL |
| 4 | AIV3-4 | SPOOL | 1 | ST STEEL |
| 3 | AIV3-3 | BUTTON ACTUATOR | 1 | ALUMINIUM |
| 2 | AIV3-2 | PLUG NUT | 1 | BRASS |
| 1 | AIV3-1 | BODY | 1 | ALUMINIUM |
| ITEM | PART NUMBER | DESCRIPTION | QTY. | MATERIAL |

METERS - VALVES - VENTS - MANHOLES - HOSEREELS - OVERFILL PROTECTION - LOADING ARMS - ELECTRONIC DIPSTICKS



LIQUIP INTERNATIONAL PTY LTD

13 HUME ROAD SMITHFIELD SYDNEY N.S.W. AUSTRALIA 2164
 Phone: +61 2 9725-9000 Fax: +61 2 9725-1252 Web: www.liquip.com

X2005

Sheet 1 of 2
 Issue: J

AIR INTERLOCK VALVE

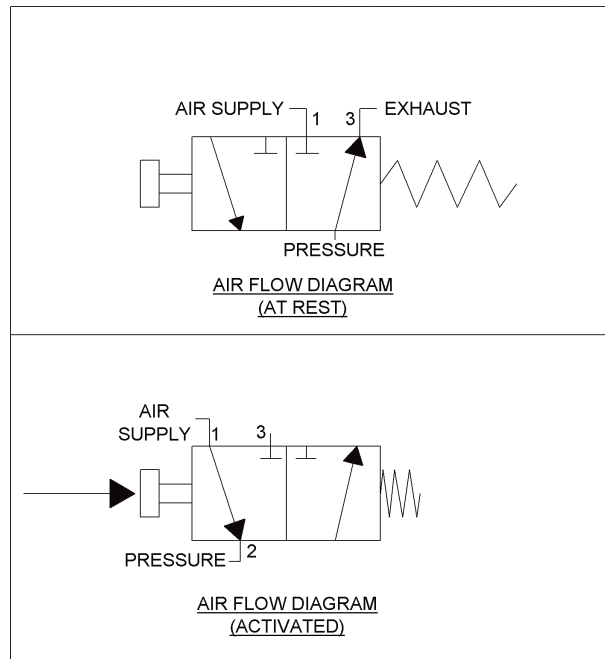
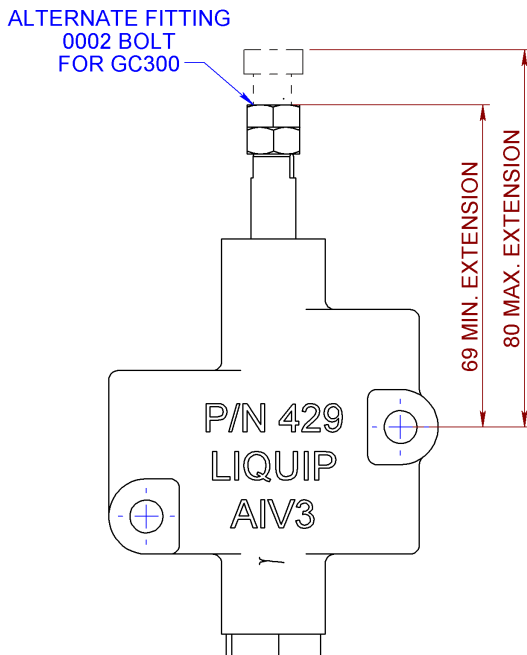
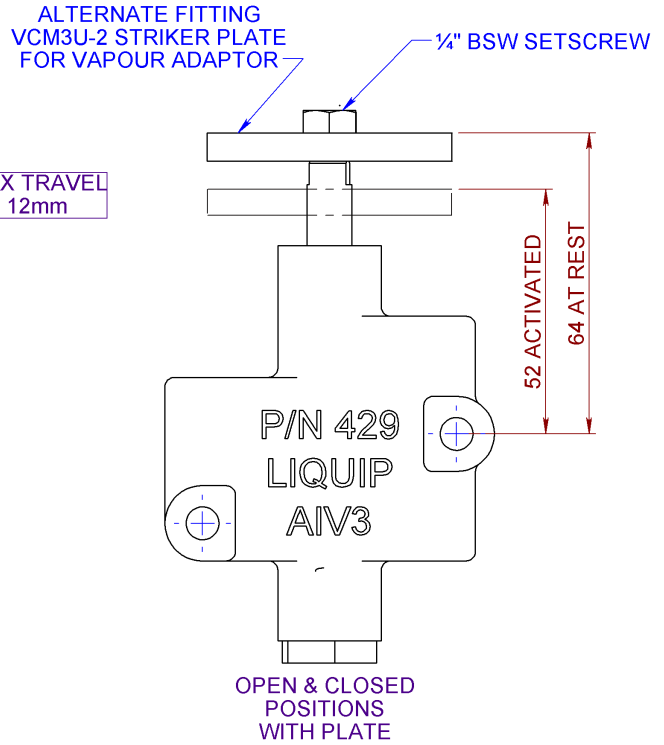
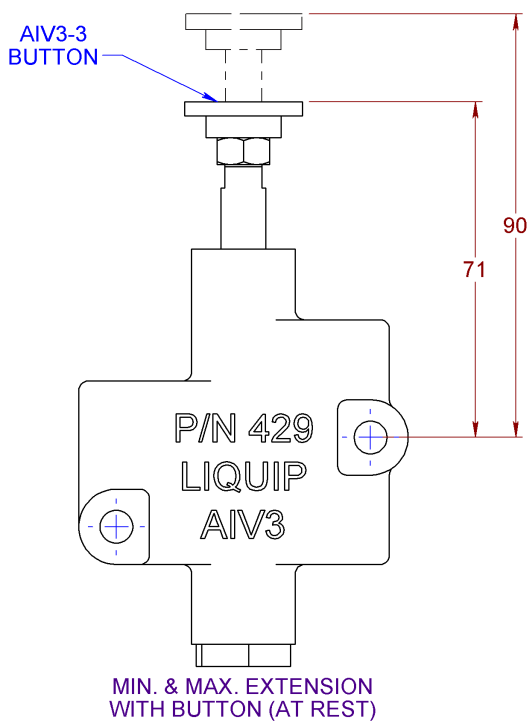

METERS - VALVES - VENTS - MANHOLES - HOSEREELS - OVERFILL PROTECTION - LOADING ARMS - ELECTRONIC DIPSTICKS

LIQUIP

PART OF OPW A BOWEN COMPANY

LIQUIP INTERNATIONAL PTY LTD

13 HUME ROAD SMITHFIELD SYDNEY N.S.W. AUSTRALIA 2164
Phone: +61 2 9725-9000 Fax: +61 2 9725-1252 Web: www.liquip.com

X2005

Sheet 2 of 2
Issue: J