

R-SERIES LIGHTWEIGHT HIGH PRESSURE HOSEREELS

Liquip's all new R-Series drum style hosereels provide the perfect balance of strength and reduced weight to allow for increased payload capacity.

Liquip hosereels are designed for tough conditions and the R-Series is no exception. Beyond incorporating Liquip's proven technologies that work flawlessly in high pressure applications, Liquip's efforts were concentrated on re-engineering the hosereel design to reduce weight whilst withstanding the harshest operating environments and offering exceptional quality and usability.

Featuring an all new stainless steel manifold, aluminium base frame, drum and cheek plates, and a self aligning bearing, it's clear that no stone has been left unturned during the development of the R-Series reel.

The R-series is suitable for use in petroleum, aviation applications (Use RxxxHPLPG for LPG applications).



R310HP model shown

Key Features

- Lightweight design for increased payload capacity.
- 38mm flow path throughout.
- The stainless steel manifold and 1½" BSPT gooseneck allow for multiple product compatibility.
- The aluminium exterior eliminates the need for additional painting or coatings.
- Manifold, shafts and seal components can be easily accessed from the outside providing ease of service and maintenance.
- R series reels can be driven manually, hydraulically or pneumatically.
- Liquip's pneumatic motor is easy to operate and quiet.
- Liquip's pneumatic motor can be effectively operated using Liquip's control valve (P/N 9953)
- Incorporates a flexible hose connection to ensure longevity of the hosereel.
- Mounting positions allow for easy retro fitting when replacing prior HR series hosereels.
- A range of drum lengths available with the same hose capacity as their predecessors.
- Left or Right hand configurable to ensure flexibility during installation.
- Supplied as standard with an anti-rotation lock to prevent hose unravelling.
- All reels are Australian made and supported through Liquip's distribution network.
- Standard Gooseneck is 1½" BSPT and can be reduced as required.

Technical Information

Base Hosereel		Pneumatic Motor	
Max allowable working pressure	2,100 kPa	Max Pressure	620 kPa (6.2 Bar/90 psi)
Periodic Service	Annually - check O-rings and replace as required.	Min Pressure	400 kPa (4 Bar/60 psi)
Mounting	4 x M10 Bolts - see mounting footprint on following pages.	Hosereel Speed	56 RPM - AR310HP 61 RPM - AR460HP/AR610HP
Inlet and Outlet	Reducers can be used to suit the following diameter hose: 25mm (1") 32mm (1¼") 38mm (1½")(Standard)	Air Tank Size	200 litres
1½" BSPT as Standard		Max Air Consumption	1100 (NI/min) at 620 kPa - AR310HP 1,600 (NI/min) at 620kPa - AR460HP/ AR610HP
Rewind Options	Manual, Hydraulic or Pneumatic (air)	Hydraulic Motor	
Drum widths and weights (less motors)	310mm (12") - 19kg 460mm (18") - 20kg 610mm (24") - 21kg	Max Inlet Pressure	17,500 kPa (175bar/2,538 psi)
Materials	-Stainless steel 304 Manifold & Gooseneck and Wetted components -Aluminium cheek plates and drum. -Nitrile seals. (Viton seals available upon request).	Max Fluid Flowrate	60 LPM
		FT1251538 Flow Control Valve	210 Bar Working Pressure 30 LPM Recommended Max Flow Rate
		5412 Hydraulic Control Valve	4 Spool only, 45 LPM rated flow
		Manual Rewind	
		Winding Force Requirement	15 kg (force)

Ordering Information

Configurations and example part number

Rewind Mechanism

AR = Pneumatic rewind

Motor included. Control sold separately

FR = Manual rewind

Rewind handle included.

HR = Hydraulic rewind

Motor included loose as a kit HRxxxHPZ.

Control sold separately

R = Hydraulic ready

Motor and Control sold separately

Width of reel

310 = 310mm (12")

460 = 460mm (18")

610 = 610mm (24")

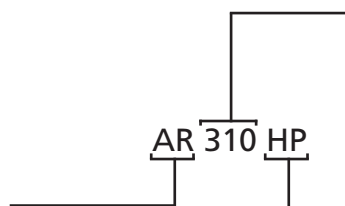

Reel Style

HP = High Pressure Drum comes with 1½" BSPT Swivel & Gooseneck

HPC = High Pressure Cartwheel (coming soon)

Nickel Plated and Galvanised models available upon request

Associated Equipment

- **R-Series Hosereel LPG Spec:** RxxxHPLPG
- **Cartwheel/Catherine Style Hosereels- Standard:** AHR250 series.
- **Aviation Drum style hosereels:** AHR250D series (suit 2" hoses).
- **Recommended hose:** Continental / Elaflex / Alfagomma suction or delivery hose.
- **Recommended swivels:** Liquip SJ series swivels or OPW swivels.
- **Industrial nozzles:**
 - 210L0104LLIQUIP: Nozzle 1¼" BSPP C/W spout OPW 210 series High Flow
 - 210L0105LLIQUIP: Nozzle 1½" BSPP C/W spout OPW 210 series High Flow

Hosereel capacity in metres

Hose Size (NB)	Beads	R310HP	R460HP	R610HP
¾"	no beads	62	93	137
1"	no beads (with beads)	39 (11)	64 (18)	88 (25)
1¼"	no beads (with beads)	24 (9)	35 (14)	53 (21)
1½"	no beads (with beads)	22 (4)	33 (5)	48 (8)

Category	Item	Description
Goosenecks	R310HP-4	Gooseneck S/S - 1½" BSPT
Pneumatic Rewind	5383	Pneumatic motor for AR310HP
	9950	Pneumatic motor for AR460HP and AR610HP
	R310HP-26	5383 Pneumatic motor with gearbox assembly to suit AR310HP series hosereels
	R310HP-26L	9950 Pneumatic motor with gearbox assembly to suit AR460HP/AR610HP series hosereels
Hydraulic Rewind	1295	Hydraulic motor Danfoss
	5412	Hydraulic Control Valve (Motor Spool 2000psi Relief Spring Centered Detent to port A)
	FT1251538	FLOW CONTROL VALVE 3/8 ADJUSTABLE
Manual Rewind	R310HP-31	Manual crank handle and gearbox assembly
	R310HP-34	Handle Assembly only

R-SERIES LIGHTWEIGHT HIGH PRESSURE HOSEREELS

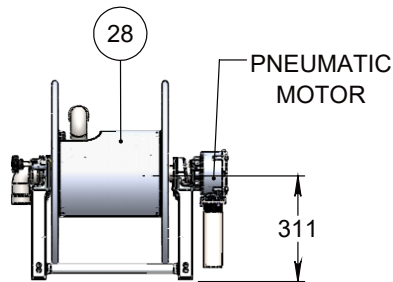
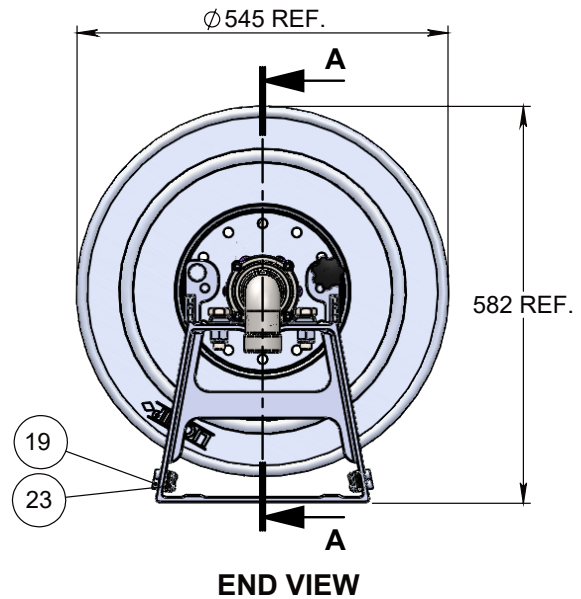
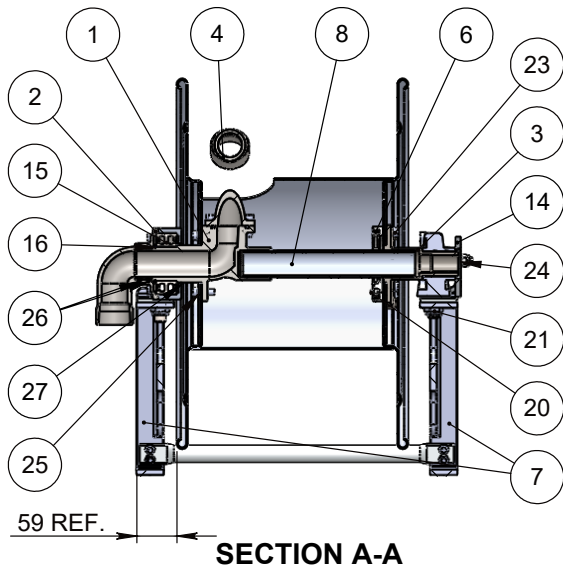
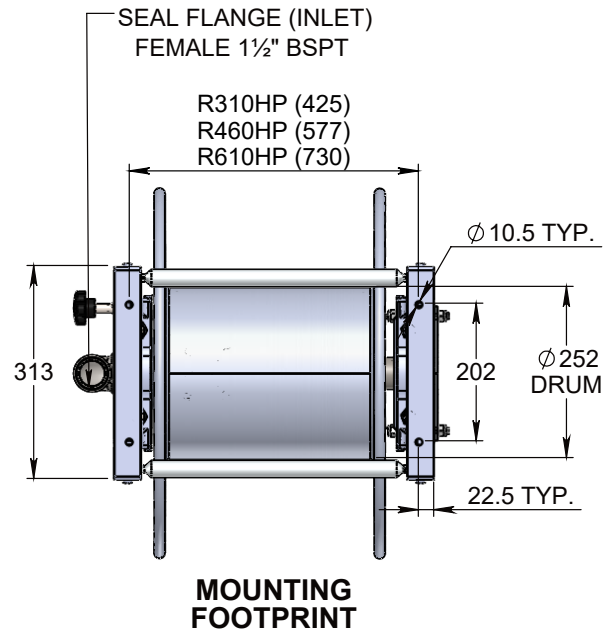
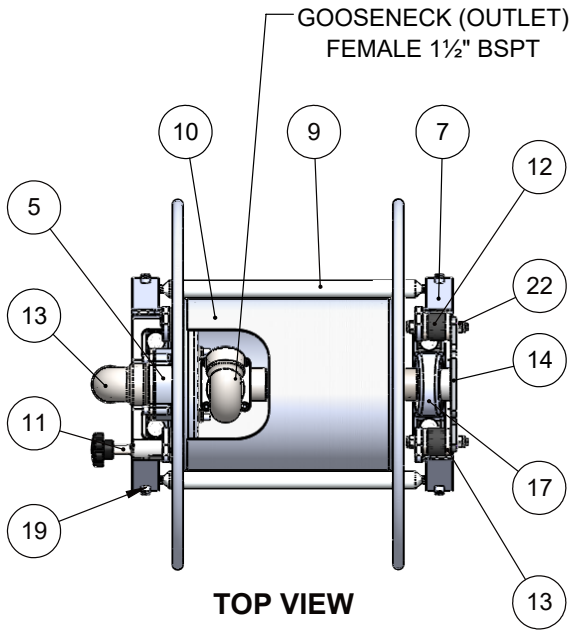

AR SERIES REEL
ARxxxHP

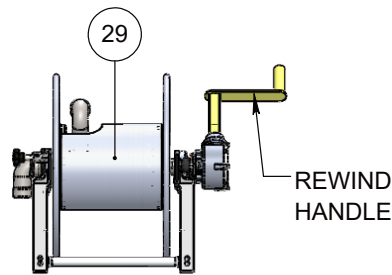

FR SERIES REEL
FRxxxHP

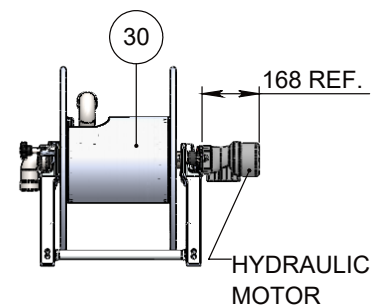

HR SERIES REEL
HRxxxHPZ

BOM - R-Series Lightweight High Pressure Hosereels						
ITEM NO.	PART NUMBER	DESCRIPTION	R310HP QTY.	R460HP QTY.	R610HP QTY.	MATERIAL
1	R310HP-1	MANIFOLD	1	1	1	ST STEEL
2	R310HP-2	SEAL FLANGE	1	1	1	ST STEEL
3	R310HP-3	INPUT SHAFT-FLANGE	1	1	1	ST STEEL
4	R310HP-4	GOOSENECK	1	1	1	ST STEEL
5	R310HP-5	BEARING HOUSING	1	1	1	ALUMINIUM
6	R310HP-6	BACKING PLATE	1	1	1	ALUMINIUM
7	R310HP-7	A-FRAME SUPPORT	2	2	2	ALUMINIUM
8	R310HP-8	CONNECTING TUBE	1	-	-	ALUMINIUM
	R460HP-8	CONNECTING TUBE	-	1	-	ALUMINIUM
	R610HP-8	CONNECTING TUBE	-	-	1	ALUMINIUM
9	R310HP-9	TUBE (25 x 3 x I.D 19mm)	2	-	-	ALUMINIUM
	R460HP-9	TUBE (25 x 3 x I.D 19mm)	-	2	-	ALUMINIUM
	R610HP-9	TUBE (25 x 3 x I.D 19mm)	-	-	2	ALUMINIUM
10	R310HP-23	HOSEREEL DRUM	1	-	-	ALUMINIUM
	R460HP-23	HOSEREEL DRUM	-	1	-	ALUMINIUM
	R610HP-23	HOSEREEL DRUM	-	-	1	ALUMINIUM
11	R310HP-12	LOCK PIN ASSEMBLY	1	1	1	SS & AL
12	R310HP-15	RUBBER MOUNT	2	2	2	STEEL & RUBBER
13	R310HP-16	SPACER	4	4	4	ST STEEL
14	R310HP-22	BRACKET MOTOR MOUNT	1	1	1	ST STEEL
15	5375	DOUBLE ROW BALL BEARING	1	1	1	STEEL
16	5376	EXTERNAL CIRCLIP	1	1	1	STEEL
17	4637	BEARING & BLOCK	1	1	1	STEEL & IRON
18	6705	M16 x 50 Z/P	4	4	4	Z/P STEEL
19	4942	M8 x 25 SS	28	28	28	ST STEEL
20	6533	M6 x 20 SS	2	2	2	ST STEEL
21	55023	M16 NYLOC NUT	4	4	4	Z/P STEEL
22	4981	M10 NYLOC NUT	4	4	4	Z/P STEEL
23	6625	M8 NYLOC NUT	8	8	8	Z/P STEEL
24	5288	M10 WASHER Z/P	4	4	4	Z/P STEEL
25	6605	M8 WASHER SS	6	6	6	ST STEEL
26	5374	O-RING for R310HP-1	3	3	3	NBR
27	5378	O-RING for R310HP-5	1	1	1	NBR

AR, FR & HR SERIES LIGHTWEIGHT REEL ASSEMBLY								
ITEM	PART #	R310HP QTY.	R460HP QTY.	R610HP QTY.	R310HP-26 QTY.	R310HP-26L QTY.	R310HP-31 QTY.	1295 QTY.
28	AR310HP	1	-	-	1	-	-	-
	AR460HP	-	1	-	-	1	-	-
	AR610HP	-	-	1	-	1	-	-
29	FR310HP	1	-	-	-	-	1	-
	FR460HP	-	1	-	-	-	1	-
	FR610HP	-	-	1	-	-	1	-
30	HR310HPZ	1	-	-	-	-	-	1
	HR460HPZ	-	1	-	-	-	-	1
	HR610HPZ	-	-	1	-	-	-	1

HOSEREEL SUB-ASSEMBLIES AND KEY SPARE PARTS

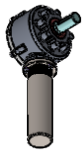

**PNEUMATIC MOTOR & GEARBOX ASSEMBLY-SMALL
PART # : R310HP-26**

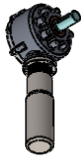

**PNEUMATIC MOTOR & GEARBOX ASSEMBLY-LARGE
PART # : R310HP-26L**

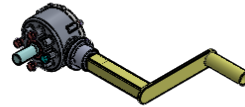

**GEARBOX & REWIND HANDLE
PART # : R310HP-31
MANUAL REWIND ASSEMBLY**

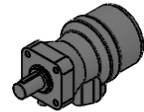

**HYDRAULIC MOTOR
PART # : 1295**



**PART # : 5383
PNEUMATIC MOTOR SMALL**

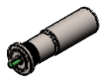

**PART # : 9950
PNEUMATIC MOTOR LARGE**



**PART # : R310HP-4
GOOSENECK S/S
1½" BSPT**

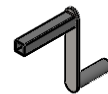

**PART # : R310HP-34
MANUAL REWIND HANDLE ONLY**



**PART # : VITON SEAL KIT
5374V ORING VITON
5378V ORING VITON**

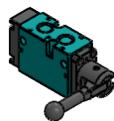

**PART # : 9953
VALVE PULL HANDLE
LEVER/ DETENT PERP
C/W FITTINGS**



**PART # : 5412
HYDRAULIC CONTROL VALVE (MOTOR SPOOL 2000PSI RELIEF SPRING CENTERED DETENT TO PORT A)**

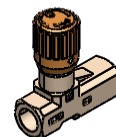

**PART # : FT1251538
FLOW CONTROL VALVE 3/8
ADJUSTABLE**